





EINBAUHALTER



CARTRIDGES



КАРТРИДЖИ



CARTOUCHES



CARTUCCE



刀头



EINBAUHALTER
CARTRIDGES
КАРТРИДЖИ

CARTOUCHES
CARTUCCE
刀头

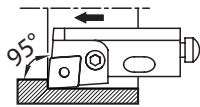

PCLN

Page 478

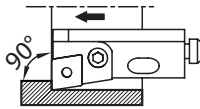

PCFN

Page 478

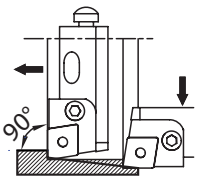

PCGN

Page 479

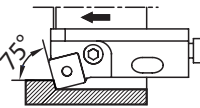

PSKN

Page 479

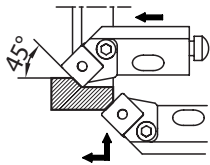

PSSN

Page 480

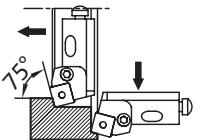

PSRN

Page 480

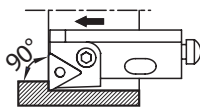

PTFN

Page 481

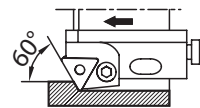

PTWN

Page 481

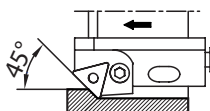

PTSN

Page 482

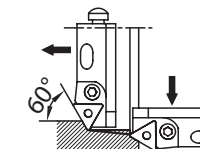

PTTN

Page 482

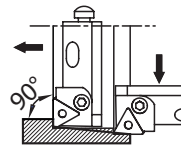

PTGN

Page 483

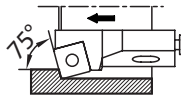

SSKC

Page 483

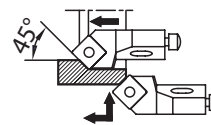

SSSC

Page 484



SCLC

Page 484

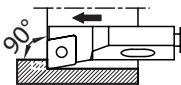

SCFC

Page 485

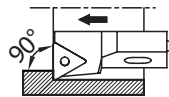

STFC

Page 485

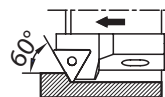

STWC

Page 486

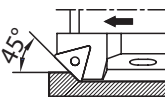

STSC

Page 486

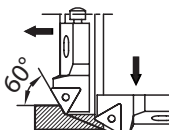

STTC

Page 487

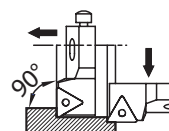

STGC

Page 487

BESTELNUMMERN-SCHLÜSSEL FÜR EINBAUHALTER
CODE KEY FOR CARTRIDGES
СИСТЕМА ОБОЗНАЧЕНИЯ КАРТРИДЖЕЙ

CODIFICATION DES CARTOUCHES
CHIAVE DEI CODICI DELLE CARTUCCE
刀头代码键

①

Spannsystem
Clamping system
Système de serrage
Sistema di bloccaggio
Система крепления СМП
夹紧系统

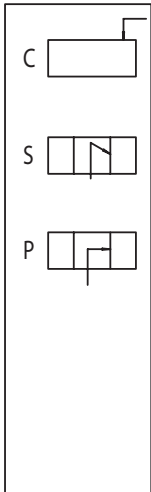

②

Platteform
Insert Shape
Forme des plaquettes
Forma degli inserti
Форма пластины
插件形状

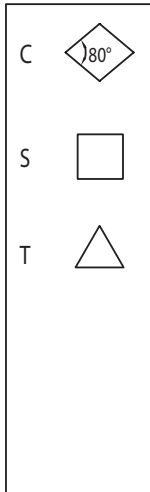

③

Einbauhalterauführung, Einstellwinkel
Cartridge style, entering angle
Type de cartouche, angle d'attaque
Tipo di cartuccia, angolo di registrazione
Угол в плане
刀头样式, 进刀角度

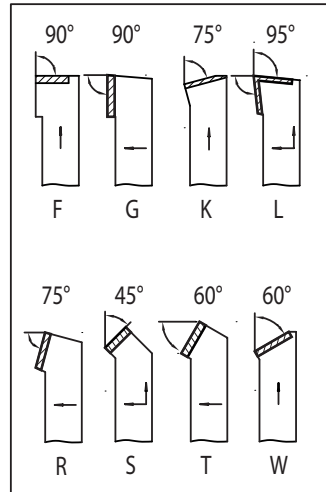

④

Freiwinkel
Clearance angle
Angle de depouil
Angolo di spoglio
Задний угол
间隙角度

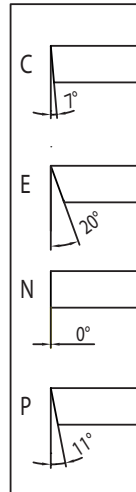

⑤

Vorshubrichtung
Freeding direction
Sens de l'avance
Senso di avanzamento
Исполнение (прав./лев.)
进给方向

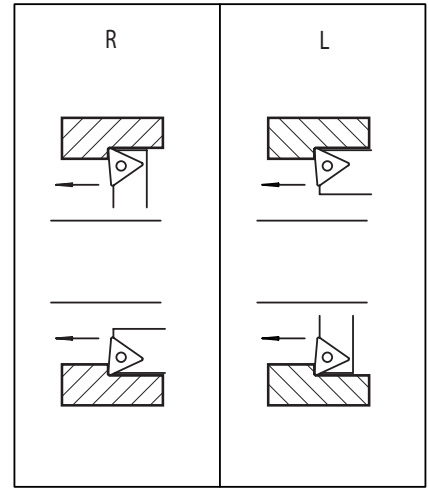

⑥

Schneidkantenhöhe
Cutting edge height
Hauteur de l'arête de coupe
Altezza del tagliente
Высота режущей кромки
切削刃高度

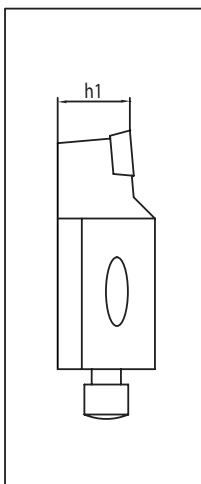

⑦

Haltertyp
Type of tool
Type d'outil
Tipo di utensile
Тип инструмента
工件类型

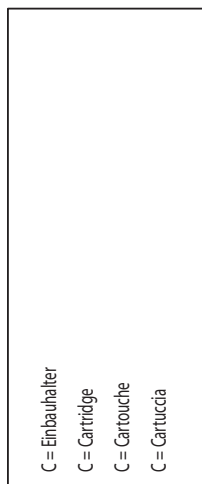

⑧

Ausführung
Type of design
Construction
Tipo di progetto
Тип конструкции
设计类型

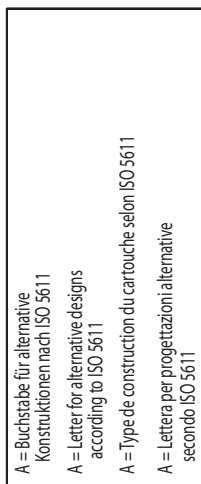

⑨

Werkzeuglänge
Tool length
Longueur de l'outil
Lunghezza utensile
Длина инструмента
工件长度

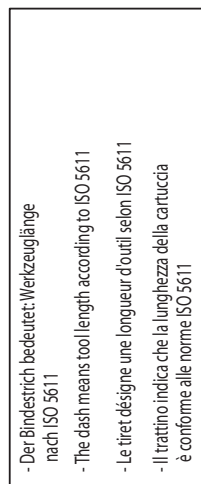

⑩

Schneidkantenlänge
Insert cutting edge length
Longueur des arêtes des plaquettes
Lunghezza del profilo inserto
Длина режущей кромки
插件的切削边缘长度

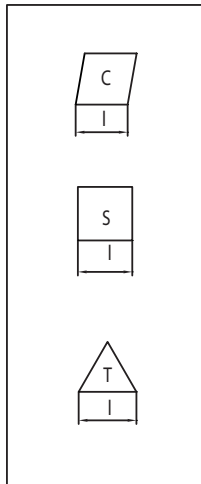

PCLN

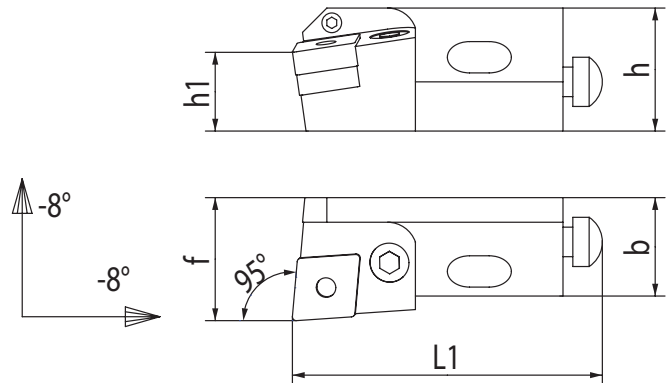

| Code N. | h | h1 | b | L1 | f | Dmin. | Inserts N. | Support pad | Lever | Screw | Shim pin | Chiave |
|-----------------|----|----|----|-----|----|-------|-------------|-------------|-------|-------|----------|--------|
| PCLNR/L 12CA-12 | 20 | 12 | 15 | 55 | 20 | 50 | CNM..1204.. | | | | | 2.5 |
| PCLNR/L 16CA-12 | 25 | 16 | 20 | 63 | 25 | 55 | CNM..1204.. | KA1 | K112 | K122 | KD1 | 3 |
| PCLNR/L 20CA-16 | 30 | 20 | 20 | 70 | 25 | 70 | CNM..1606.. | KY2 | KB5 | KC5c | KD5 | 3 |
| PCLNR/L 25CA-19 | 38 | 25 | 25 | 100 | 32 | 100 | CNM..1906.. | KA2 | K113 | K123 | K131 | 4 |

PCFN

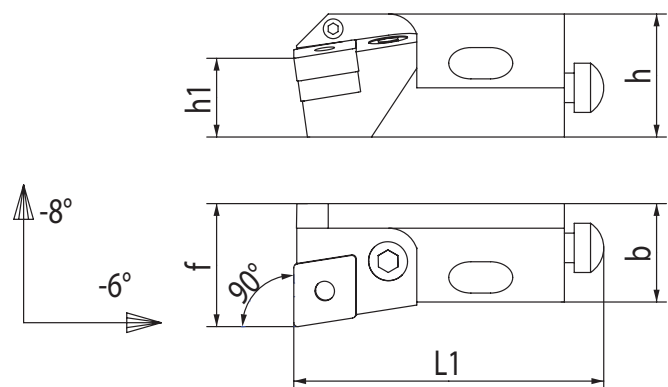

| Code N. | h | h1 | b | L1 | f | Dmin. | Inserts N. | Support pad | Lever | Screw | Shim pin | Chiave |
|-----------------|----|----|----|-----|----|-------|-------------|-------------|-------|-------|----------|--------|
| PCFNR/L 12CA-12 | 20 | 12 | 15 | 55 | 20 | 50 | CNM..1204.. | | | | | 2.5 |
| PCFNR/L 16CA-12 | 25 | 16 | 20 | 63 | 25 | 55 | CNM..1204.. | KA1 | K112 | K122 | KD1 | 3 |
| PCFNR/L 20CA-16 | 30 | 20 | 20 | 70 | 25 | 70 | CNM..1606.. | KY2 | KB5 | KC5c | KD5 | 3 |
| PCFNR/L 25CA-19 | 38 | 25 | 25 | 100 | 32 | 100 | CNM..1906.. | KA2 | K113 | K123 | K131 | 4 |

PCGN

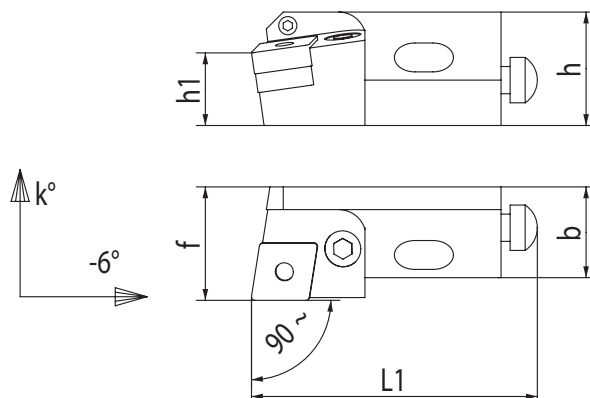

| Code N. | h | h1 | b | L1 | f | Dmin. | k | Inserts N. | Support pad | Lever | Screw | Shimpin | Chiave |
|-----------------|----|----|----|-----|----|-------|------|-------------|-------------|-------|-------|---------|--------|
| PCGNR/L 16CA-12 | 25 | 16 | 20 | 63 | 25 | 60 | -10° | CNM..1204.. | | | | | |
| PCGNR/L 25CA-19 | 38 | 25 | 25 | 100 | 32 | 100 | -8° | CNM..1906.. | | | | | |

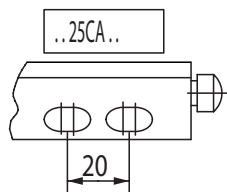

| Ricambi cartucce per ... | Screw | Chiave | Screw | Screw | Chiave |
|--------------------------|--------|--------|-------|------------|--------|
| ..12CA.. | KGRL12 | 2 | KVA5 | KVB12 | 4 |
| ..16CA.. | KGRL16 | 2.5 | KVA6 | KVB16 | 5 |
| ..20CA.. | KGRL20 | 2.5 | KVA6 | KVB20 | 5 |
| ..25CA.. | KGRL25 | 3 | KVA8 | KVB25(n°2) | 6 |

PSKN

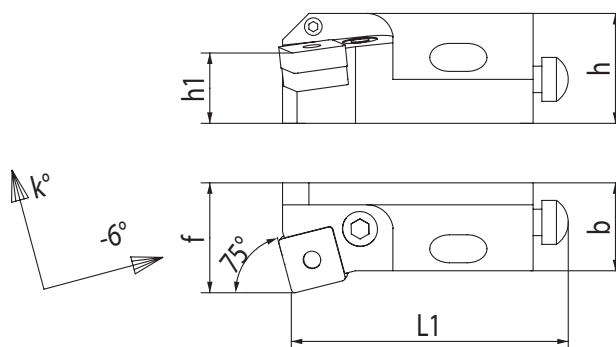

| Code N. | h | h1 | b | L1 | f | Dmin. | k | Inserts N. | Support pad | Lever | Screw | Shimpin | Chiave |
|-----------------|----|----|----|-----|----|-------|-----|-------------|-------------|-------|-------|---------|--------|
| PSKNR/L 12CA-12 | 20 | 12 | 15 | 55 | 20 | 50 | -8° | SNM..1204.. | | | | | 2.5 |
| PSKNR/L 16CA-12 | 25 | 16 | 20 | 63 | 25 | 55 | -7° | SNM..1204.. | | | | | 3 |
| PSKNR/L 20CA-15 | 30 | 20 | 20 | 70 | 25 | 70 | -8° | SNM..1506.. | | | | | 4 |
| PSKNR/L 25CA-19 | 38 | 25 | 25 | 100 | 32 | 100 | -7° | SNM..1906.. | | | | | |

PSSN

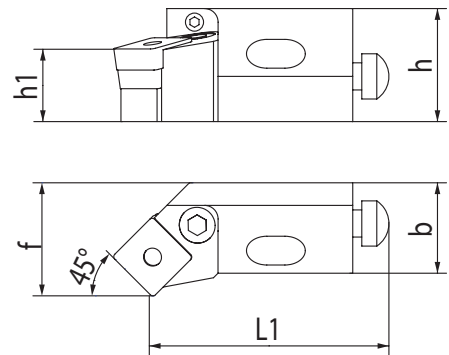

| Code N. | h | h1 | b | L1 | f | Dmin. | k1 | k2 | Inserts N. | Support pad | Lever | Screw | Shim pin | Chiave |
|-----------------|----|----|----|----|----|-------|-----|------|-------------|-------------|-------|-------|----------|--------|
| PSSNR/L 12CA-12 | 20 | 12 | 15 | 47 | 20 | 50 | -3° | -10° | SNM..1204.. | | | | | |
| PSSNR/L 16CA-12 | 25 | 16 | 20 | 53 | 25 | 55 | 0° | -11° | SNM..1204.. | KA4 | K112 | K122 | KD1 | 3 |
| PSSNR/L 20CA-15 | 30 | 20 | 20 | 60 | 25 | 70 | -3° | -10° | SNM..1506.. | KY1 | KB5 | KC5c | KD5 | 3 |

PSRN

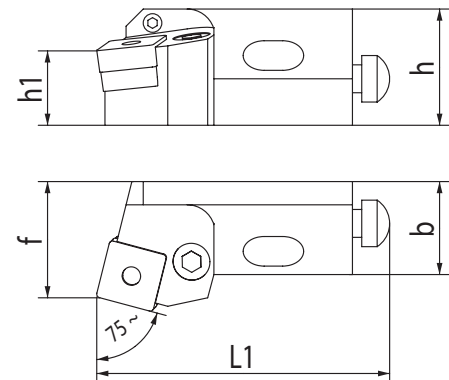
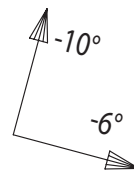

| Code N. | h | h1 | b | L1 | f | Dmin. | Inserts N. | Support pad | Lever | Screw | Shim pin | Chiave |
|-----------------|----|----|----|----|----|-------|-------------|-------------|-------|-------|----------|--------|
| PSRNR/L 16CA-12 | 25 | 16 | 20 | 63 | 25 | 60 | SNM..1204.. | | | | | |
| PSRNR/L 20CA-15 | 30 | 20 | 20 | 70 | 25 | 70 | SNM..1506.. | KY1 | KB5 | KC5c | KD5 | 3 |

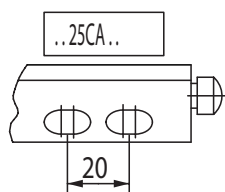

| Ricambi cartucce per ... | Screw | Chiave | Screw | Screw | Chiave |
|--------------------------|--------|--------|-------|------------|--------|
| ..12CA.. | KGRL12 | | | | |
| ..16CA.. | KGRL16 | 2.5 | KVA6 | KVB16 | 5 |
| ..20CA.. | KGRL20 | 2.5 | KVA6 | KVB20 | 5 |
| ..25CA.. | KGRL25 | 3 | KVA8 | KVB25(n°2) | 6 |

PTFN

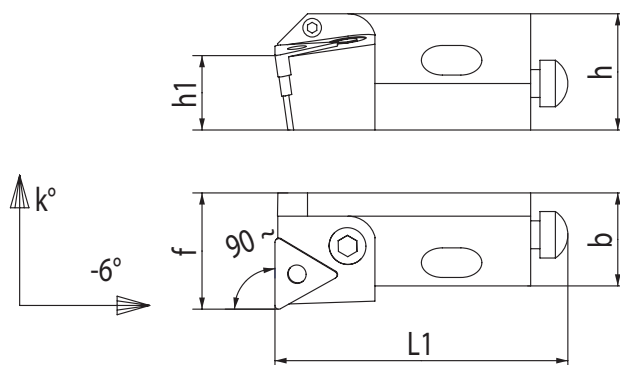

| Code N. | h | h1 | b | L1 | f | Dmin. | k | Inserts N. | Support pad | Lever | Screw | Shimpin | Chiave |
|-----------------|----|----|----|-----|----|-------|-----|-------------|-------------|-------|-------|---------|--------|
| PTFNR/L 12CA-16 | 20 | 12 | 15 | 55 | 20 | 50 | -9° | TNM..1604.. | | | | | 2 |
| PTFNR/L 16CA-16 | 25 | 16 | 20 | 63 | 25 | 55 | -8° | TNM..1604.. | KA6 | KB4 | KC3 | KD3 | 2.5 |
| PTFNR/L 20CA-22 | 30 | 20 | 20 | 70 | 25 | 70 | -8° | TNM..2204.. | KA7 | KB1 | KC1 | KD1 | 3 |
| PTFNR/L 25CA-27 | 38 | 25 | 25 | 100 | 32 | 100 | -9° | TNM..2706.. | KH1 | KH2 | KH5 | KD5 | 3 |

PTWN

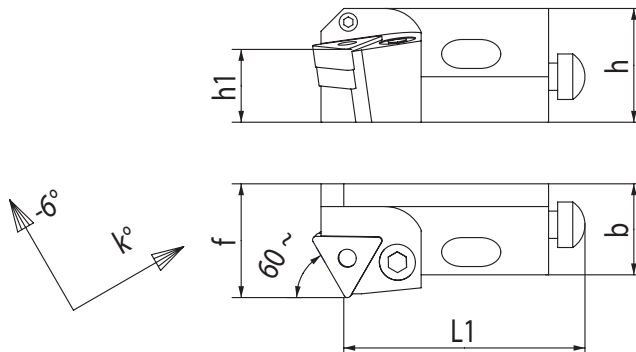

| Code N. | h | h1 | b | L1 | f | Dmin. | k | Inserts N. | Support pad | Lever | Screw | Shimpin | Chiave |
|-----------------|----|----|----|----|----|-------|-----|-------------|-------------|-------|-------|---------|--------|
| PTWNR/L 12CA-16 | 20 | 12 | 15 | 47 | 20 | 50 | -7° | TNM..1604.. | | | | | 2 |
| PTWNR/L 16CA-16 | 25 | 16 | 20 | 53 | 25 | 55 | -6° | TNM..1604.. | KA6 | KB4 | KC3 | KD3 | 2.5 |
| PTWNR/L 20CA-22 | 30 | 20 | 20 | 60 | 25 | 70 | -6° | TNM..2204.. | KA7 | KB1 | KC1 | KD1 | 3 |

PTSN

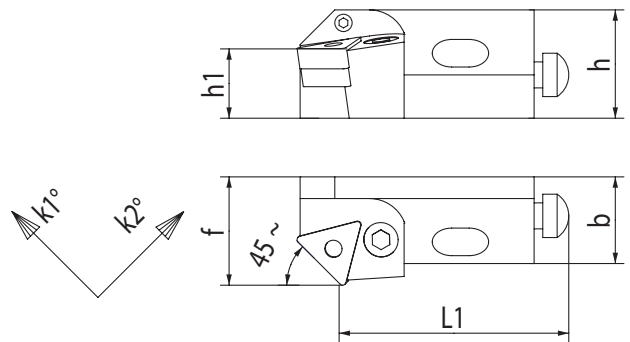

| Code N. | h | h1 | b | L1 | f | Dmin. | k1 | k2 | Inserts N. | Support pad | Lever | Screw | Shim pin | Chiave |
|-----------------|----|----|----|----|----|-------|-----|------|-------------|-------------|-------|-------|----------|--------|
| PTSNR/L 12CA-16 | 20 | 12 | 15 | 47 | 20 | 50 | -3° | -10° | TNM..1604.. | | | | | |
| PTSNR/L 16CA-16 | 25 | 16 | 20 | 53 | 25 | 55 | 0° | -11° | TNM..1604.. | KA6 | KB4 | KC3 | KD3 | 2.5 |
| PTSNR/L 20CA-22 | 30 | 20 | 20 | 60 | 25 | 70 | 0° | -11° | TNM..2204.. | KA7 | KB1 | KC1 | KD1 | 3 |

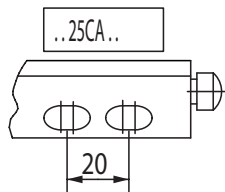

| Ricambi cartucce per ... | Screw | Chiave | Screw | Screw | Chiave |
|--------------------------|--------|--------|-------|------------|--------|
| ..12CA.. | KGRL12 | 2 | KVA5 | KVB12 | 4 |
| ..16CA.. | KGRL16 | 2.5 | KVA6 | KVB16 | 5 |
| ..20CA.. | KGRL20 | 2.5 | KVA6 | KVB20 | 5 |
| ..25CA.. | KGRL25 | 3 | KVA8 | KVB25(n°2) | 6 |

PTTN

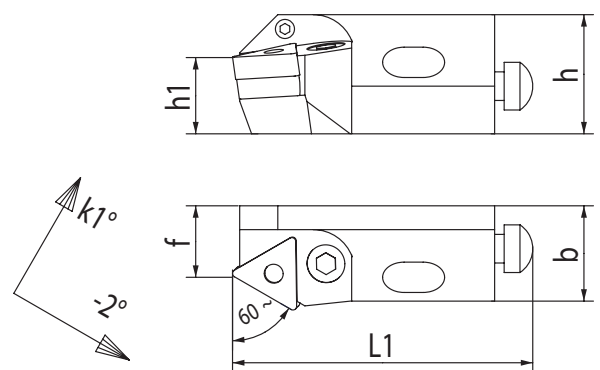

| Code N. | h | h1 | b | L1 | f | Dmin. | k | Inserts N. | Support pad | Lever | Screw | Shim pin | Chiave |
|-----------------|----|----|----|----|----|-------|------|-------------|-------------|-------|-------|----------|--------|
| PTTNR/L 12CA-16 | 20 | 12 | 15 | 55 | 13 | 50 | -9° | TNM..1604.. | | | | | |
| PTTNR/L 16CA-16 | 25 | 16 | 20 | 63 | 15 | 60 | -10° | TNM..1604.. | KA6 | KB4 | KC3 | KD3 | 2.5 |
| PTTNR/L 20CA-22 | 30 | 20 | 20 | 70 | 15 | 70 | -10° | TNM..2204.. | KA7 | KB1 | KC1 | KD1 | 3 |

PTGN

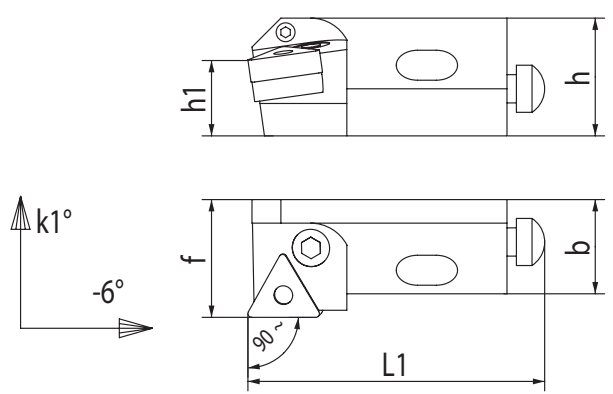

| Code N. | h | h1 | b | L1 | f | Dmin. | k | Inserts N. | Support pad | Lever | Screw | Shimpin | Chiave |
|-----------------|----|----|----|----|----|-------|------|-------------|-------------|-------|-------|---------|--------|
| PTGNR/L 12CA-16 | 20 | 12 | 15 | 55 | 20 | 50 | -10° | TNM..1604.. | | K111 | K121 | | 2 |
| PTGNR/L 16CA-16 | 25 | 16 | 20 | 63 | 25 | 60 | -10° | TNM..1604.. | KA6 | KB4 | KC3 | KD3 | 2.5 |
| PTGNR/L 20CA-22 | 30 | 20 | 20 | 70 | 25 | 70 | -8° | TNM..2204.. | KA7 | KB1 | KC1 | KD1 | 3 |

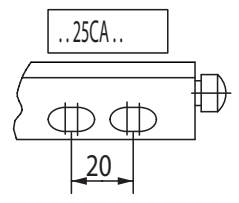

| Ricambi cartucce per ... | Screw | Chiave | Screw | Screw | Chiave |
|--------------------------|--------|--------|-------|------------|--------|
| ..12CA.. | KGRL12 | 2 | KVA5 | KVB12 | 4 |
| ..16CA.. | KGRL16 | 2.5 | KVA6 | KVB16 | 5 |
| ..20CA.. | KGRL20 | 2.5 | KVA6 | KVB20 | 5 |
| ..25CA.. | KGRL25 | 3 | KVA8 | KVB25(n°2) | 6 |

SSKC

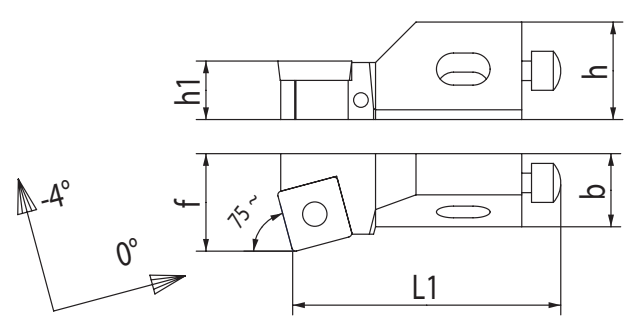

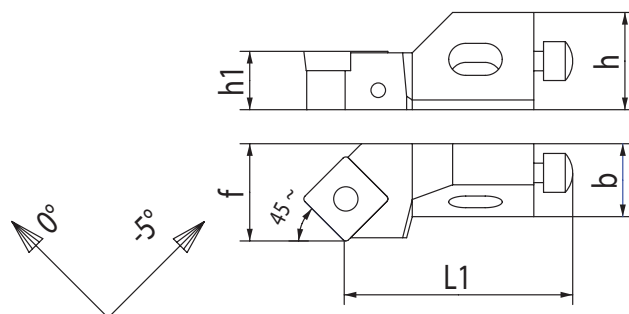

| Code N. | h | h1 | b | L1 | f | Dmin. | Inserts N. | Screw | Wrench |
|-----------------|----|----|----|----|----|-------|-------------|-------|---------|
| SSKCR/L 10CA-09 | 15 | 10 | 11 | 50 | 14 | 40 | SCM..09T3.. | KV4c | Torx 15 |
| SSKCR/L 12CA-12 | 20 | 12 | 15 | 55 | 20 | 50 | SCM..1204.. | KV5 | Torx 20 |

SSSC





| Code N. | h | h1 | b | L1 | f | Dmin. | Inserts N. |
|-----------------|----|----|----|----|----|-------|-------------|
| SSSCR/L 10CA-09 | 15 | 10 | 11 | 44 | 14 | 40 | SCM..09T3.. |
| SSSCR/L 12CA-12 | 20 | 12 | 15 | 47 | 20 | 50 | SCM..1204.. |

| Screw | Wrench |
|--|---|
|  KV4c |  Torx 15 |
| KV5 | Torx 20 |

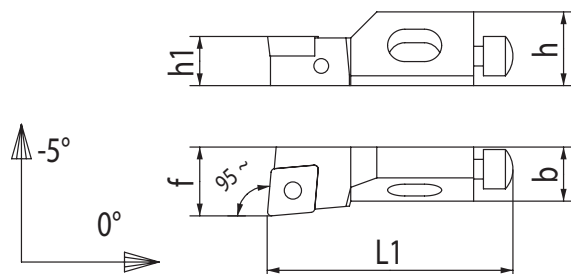
SCLC



| Code N. | h | h1 | b | L1 | f | Dmin. | Inserts N. |
|-----------------|----|----|----|----|----|-------|-------------|
| SCLCR/L 10CA-09 | 15 | 10 | 11 | 50 | 14 | 40 | CCM..09T3.. |
| SCLCR/L 12CA-12 | 20 | 12 | 15 | 55 | 20 | 50 | CCM..1204.. |

| Screw | Wrench |
|--|---|
|  KV4c |  Torx 15 |
| KV5 | Torx 20 |

SCFC

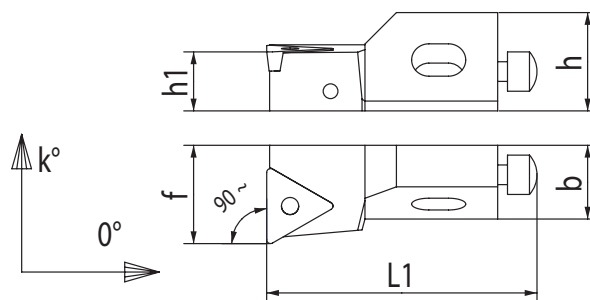

| Code N. | h | h1 | b | L1 | f | Dmin. | Inserts N. | Screw | Wrench |
|-----------------|----|----|----|----|----|-------|-------------|-------|--------|
| SCFCR/L 10CA-09 | 15 | 10 | 11 | 50 | 14 | 40 | CCM..09T3.. | | |
| SCFCR/L 12CA-12 | 20 | 12 | 15 | 55 | 20 | 50 | CCM..1204.. | | |

| Ricambi cartucce per ... | Screw | Chiave | Screw | Screw | Chiave |
|--------------------------|-------|--------|-------|-------|--------|
| ..10CA.. | | | | | |
| ..12CA.. | | | | | |

STFC

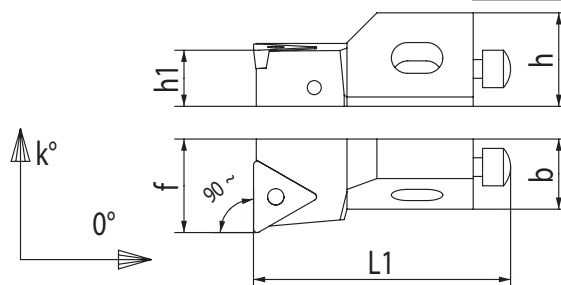

| Code N. | h | h1 | b | L1 | f | Dmin. | k | Inserts N. | Screw | Wrench | Support pad | Bush | Chiave |
|-----------------|----|----|----|----|----|-------|-----|-------------|-------|--------|-------------|------|--------|
| STFCR/L 10CA-11 | 15 | 10 | 11 | 50 | 14 | 40 | -3° | TCM..1102.. | | | | | |
| STFCR/L 12CA-16 | 20 | 12 | 15 | 55 | 20 | 50 | -3° | TCM..16T3.. | | | | | |
| STFCR/L 16CA-16 | 21 | 16 | 20 | 63 | 25 | 55 | -6° | TCM..16T3.. | | | | | |

STWC

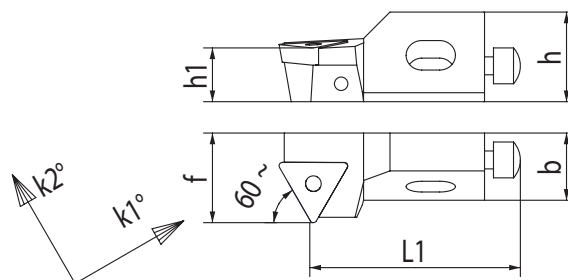

| Code N. | h | h1 | b | L1 | f | Dmin. | k1 | k2 | Inserts N. | Screw | Wrench | Support pad | Bush | Chiave |
|-----------------|----|----|----|----|----|-------|-----|-----|-------------|-------|---------|-------------|------|--------|
| STWCR/L 10CA-11 | 15 | 10 | 11 | 44 | 14 | 40 | 0° | -4° | TCM..1102.. | KV25 | Torx 7 | | | |
| STWCR/L 12CA-16 | 20 | 12 | 15 | 47 | 20 | 50 | -5° | 0° | TCM..16T3.. | KV4c | Torx 15 | | | |
| STWCR/L 16CA-16 | 21 | 16 | 20 | 53 | 25 | 55 | -5° | -5° | TCM..16T3.. | KV35 | Torx 15 | KW3 | KX01 | 3.5 |

STSC

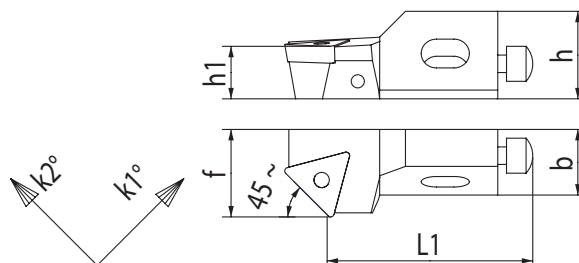

| Code N. | h | h1 | b | L1 | f | Dmin. | k1 | k2 | Inserts N. | Screw | Wrench | Support pad | Bush | Chiave |
|-----------------|----|----|----|----|----|-------|-----|-----|-------------|-------|---------|-------------|------|--------|
| STSCR/L 10CA-11 | 15 | 10 | 11 | 44 | 14 | 40 | -4° | 0° | TCM..1102.. | KV25 | Torx 7 | | | |
| STSCR/L 12CA-16 | 20 | 12 | 15 | 47 | 20 | 50 | -5° | 0° | TCM..16T3.. | KV4c | Torx 15 | | | |
| STSCR/L 16CA-16 | 21 | 16 | 20 | 53 | 25 | 55 | -6° | -3° | TCM..16T3.. | KV35 | Torx 15 | KW3 | KX01 | 3.5 |

| Ricambi cartucce per ... | Screw | Chiave | Screw | Screw | Chiave |
|--------------------------|-------|--------|-------|-------|--------|
| ..10CA.. | KGR10 | 2 | KVA5 | KVB10 | 4 |
| ..12CA.. | KGR12 | 2 | KVA5 | KVB12 | 4 |
| ..16CA.. | KGR16 | 2 | KVA6 | KVB16 | 5 |

STTC

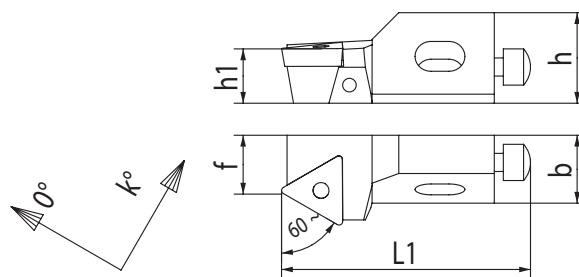

| Code N. | h | h1 | b | L1 | f | Dmin. | k | Inserts N. | Screw | Wrench | Support pad | Bush | Chiave |
|-----------------|----|----|----|----|----|-------|-----|-------------|-------|---------|-------------|------|--------|
| STTCR/L 10CA-11 | 15 | 10 | 11 | 50 | 9 | 40 | -5° | TCM..1102.. | | | | | |
| STTCR/L 12CA-16 | 20 | 12 | 15 | 55 | 13 | 50 | -3° | TCM..16T3.. | KV4c | Torx 15 | | | |
| STTCR/L 16CA-16 | 21 | 16 | 20 | 63 | 15 | 60 | -5° | TCM..16T3.. | KV35 | Torx 15 | KW3 | KX01 | 3.5 |

STGC

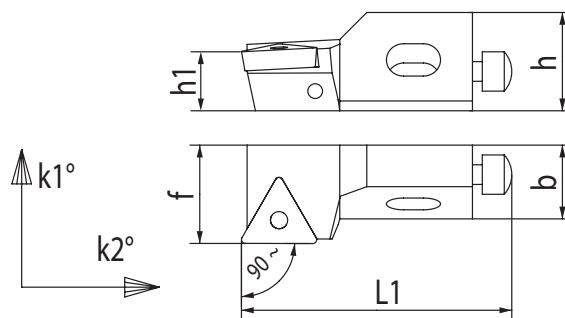

| Code N. | h | h1 | b | L1 | f | Dmin. | k1 | k2 | Inserts N. | Screw | Wrench | Support pad | Bush | Chiave |
|-----------------|----|----|----|----|----|-------|-----|-----|-------------|-------|---------|-------------|------|--------|
| STGCR/L 10CA-11 | 15 | 10 | 11 | 50 | 14 | 40 | -3° | 0° | TCM..1102.. | | | | | |
| STGCR/L 12CA-16 | 20 | 12 | 15 | 55 | 20 | 50 | -3° | 0° | TCM..16T3.. | KV4c | Torx 15 | | | |
| STGCR/L 16CA-16 | 21 | 16 | 20 | 63 | 25 | 60 | -5° | -3° | TCM..16T3.. | KV35 | Torx 15 | KW3 | KX01 | 3.5 |

| Ricambi cartucce per ... | Screw | Chiave | Screw | Screw | Chiave |
|--------------------------|-------|--------|-------|-------|--------|
| ..10CA.. | KGR10 | | | | |
| ..12CA.. | KGR12 | 2 | KVA5 | KVB10 | 4 |
| ..16CA.. | KGR16 | 2 | KVA6 | KVB16 | 5 |